

XXLS 12" Subwoofer



Type Number: 830952

Features:

This new series of state-of-the-art subwoofers continue to enhance Peerless' reputation for delivering the highest quality components for bass in the world. Called the XXLS - for "Xpanded Extra Long Stroke" - these new audio transducers add even more excursion to the Peerless XLS line, and completely eliminate distortion.

Driver features: Alu. Cone, 51mm Voice Coil, ALP

[Go to Architecture Notes](#)



Specs:

Electrical Data

Nominal impedance	Zn	4	ohm
Minimum impedance	Zmin	3	ohm
Maximum impedance	Zo	65.7	ohm
DC resistance	Re	2.6	ohm
Voice coil inductance	Le	1.6	mH
Capacitor in series with x ohm	Cc	--	uF

T-S Parameters

Resonance Frequency	fs	19.1	Hz
Mechanical Q factor	Qms	9.29	
Electrical Q factor	Qes	0.38	
Total Q factor	Qts	0.37	
Force factor	Bl	10.3	Tm
Mechanical resistance	Rms	1.69	Kg/s
Moving mass	Mms	130.6	g
Suspension compliance	Cms	0.53	mm/N
Effective cone diameter	D	24.4	cm
Effective piston area	Sd	466	cm ²
Equivalent volume	Vas	159	ltrs
Sensitivity (2.83V/1m)		91.2	dB
Ratio BL/√(Re)		6.4	
Ratio fs/Qts	F	--	

Power handling

100h RMS noise test (IEC)	--	W
Long-term Max Power (IEC 18.3)	--	W
Max linear SPL (rms) @ power	--	dB/W
Short Term Max power (IEC 18.2)	--	W

Voice Coil and Magnet Parameters

Voice coil diameter	51	mm
Voice coil height	32.6	mm
Voice coil layers	4	
Height of the gap	8	mm
Linear excursion +/-	13	mm
Max mech. excursion +/-	--	mm
Flux density of gap	--	mWb
Total useful flux	2.3	mWb
Diameter of magnet	147	mm
Height of magnet	35	mm
Weight of magnet	2.2	Kg

Notes:
IEC specs refer to IEC 60268-5 third edition.
All Tymphany products are RoHS compliant.

Frequency:

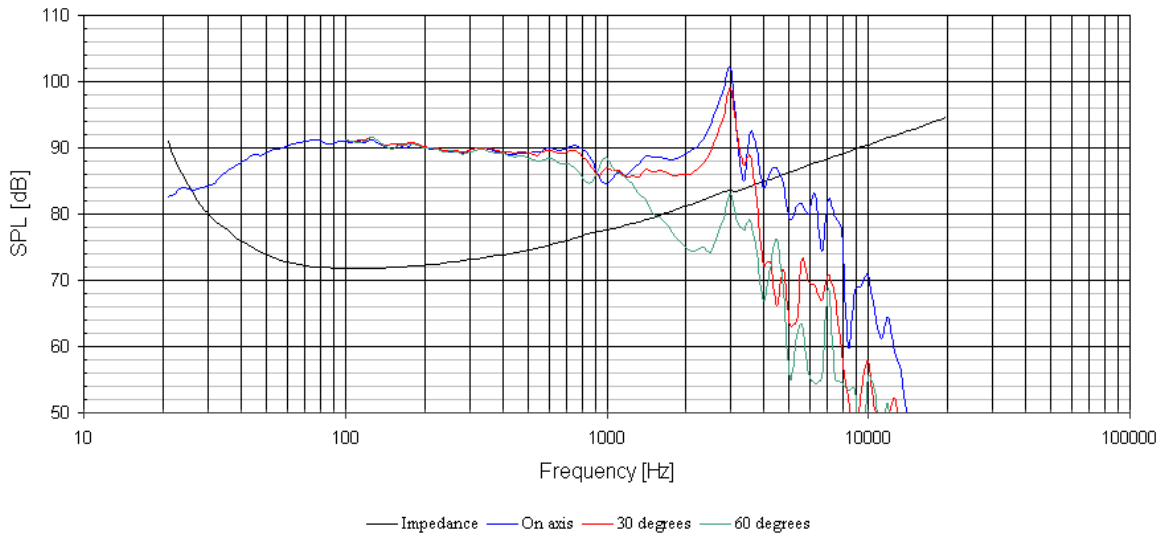

Mechanical Dimensions:

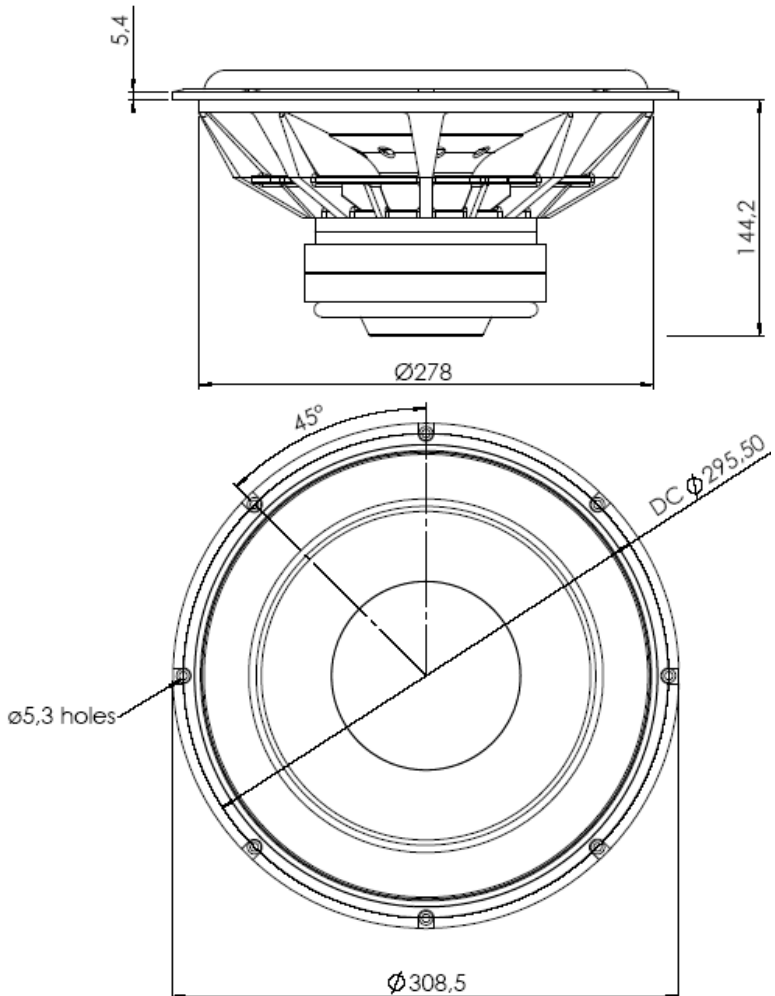

Drawing Dimensions

Outside Diameter
Flange Thickness
Magnet Diameter
Cutout Diameter

Interior Depth
Hole Diameter
Screw Circle Diameter