

Model Number: P835025
 Description: Peerless HDS 6.5" Alu cone

Revision: rev_2_0
 Date: 1-Sep-09



The new Peerless HDS product line continues the tradition of Peerless' High Definition Sound (HDS) products. A powerful ferrite magnet system is coupled to a finite element analysis designed suspension system, containing both a linear spider design and a rubber surround. The motor contains an aluminium shorting ring, which reduces coil inductance, thus providing both extended frequency response performance and reduced distortion. The long-throw voice coil ensures linear high excursion performance, needed for signal clarity. The cone necks are vented so as to reduce air compression effects under high excursion conditions. The cast aluminium basket offers structural rigidity, heat sinking capacity for the motor, and additional air venting under the spider so as to again reduce air compression effects. The cone in this model is aluminium, offering a unique visual and acoustic experience.



Mechanical 2D Drawing:

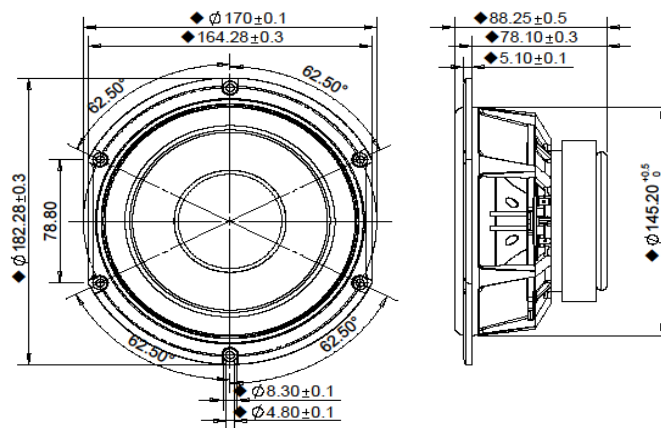

Specifications:

DC Resistance	R_{evc}	Ω	6.3	Energy Bandwidth Product	EBP	$(1/Q_{es}) \cdot f_s$	91
Minimum Impedance	Z_{min}	Ω	6.9	Moving Mass	M_{ms}	g	20.13
Voice Coil Inductance	L_e	mH	0.39	Suspension Compliance	C_{ms}	um/N	860.5
Resonant Frequency	f_s	Hz	38	Effective Cone Diameter	D	cm	13.5
Mechanical Q Factor	Q_{ms}	-	3.3	Effective Piston Area	S_D	cm ²	143.1
Electrical Q Factor	Q_{es}	-	0.42	Equivalent Volume	V_{as}	L	24.76
Total Q Factor	Q_{ts}	-	0.37	Motor Force Factor	BL	T-m	8.58
Ratio f_s / Q_{ts}	F	f_s / Q_{ts}	103	Motor Efficiency Factor	β	$(T \cdot m^2) / \Omega$	11.61
Half Space Sensitivity @ 2.83V	$dB @ 2.83V/1m$	dB	87.2	Voice Coil Former Material	VC_{fm}	-	ASV
Rated Noise Power (IEC 2685 18.1)	P	W	55	Voice Coil Inner Diameter	VC_d	mm	32.4
Test Spectrum Bandwidth	20Hz - 3000Hz	12 dB/Oct		Maximum Linear Excursion	X_{max}	mm	5.39
				Transducer Mass	-	kg	1.576

Frequency and Impedance Response:

