

WOOFER

CA15RLY

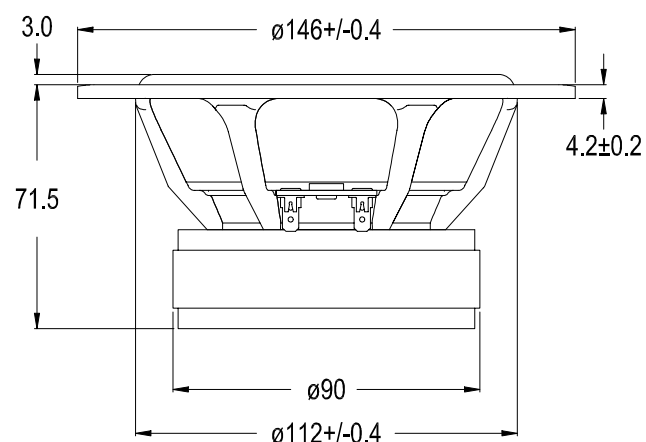
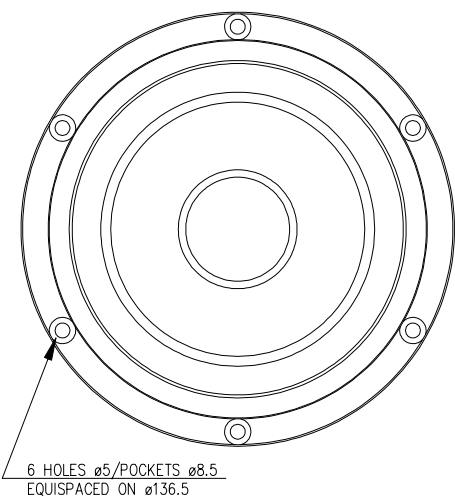

The CA15RLY is a 15 cm (5") cone driver, developed for use as a long throw high fidelity woofer or woofer/midrange unit.

The classical coated paper cone gives a smooth extended frequency response with a controlled roll off. The large magnet system, together with a very long and light weight CCAW voice coil allow good coil excursion with low distortion and good transient response.

The extremely stiff and stable injection moulded metal basket, keeps the critical components in perfect alignment. Large windows in the basket both above and below the spider reduce sound reflection, air flow noise and cavity resonance to a minimum.

NOTES

The frequency responses below show measured free field sound pressure in 0, 30, and 60 degrees angle using a standard baffle (IEC 268-5). Input 2.83 Volts RMS, microphone distance 1m. The solid line below 500 Hz is a calculated response for an infinite baffle based on the parameters given for this specific driver. The impedance is measured in free air without baffle.

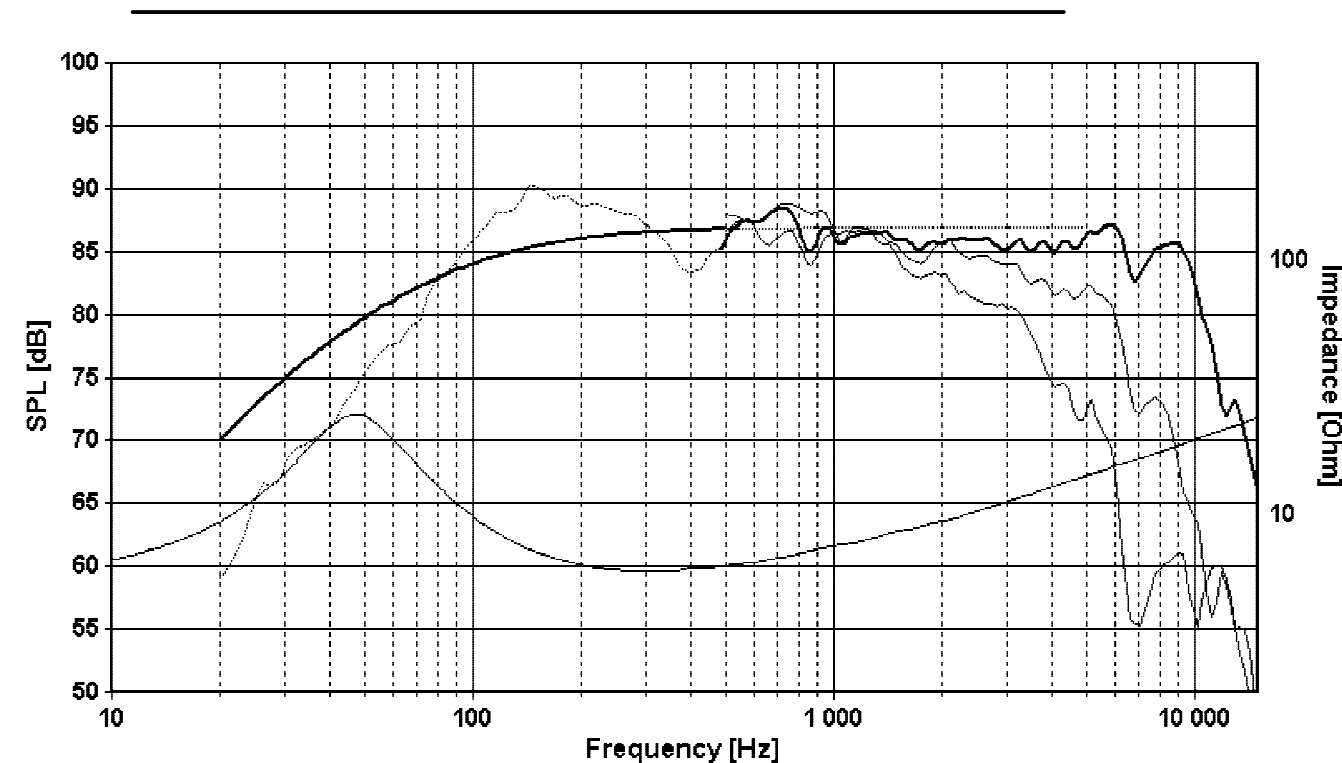

NOMINAL IMPEDANCE	8 Ohms	VOICE COIL RESISTANCE	5.5 Ohms
RECOMMENDED FREQUENCY RANGE	50-4000 Hz	VOICE COIL INDUCTANCE (EQUIVALENT)	0.76 mH
SHORT TERM MAXIMUM POWER *	250 W	FORCE FACTOR	5.4 N/A
LONG TERM MAXIMUM POWER *	60 W	FREE AIR RESONANCE	47 Hz
CHARACTERISTIC SENSITIVITY (1W,1m)	87 dB SPL	MOVING MASS	8.2 g
		AIR LOAD MASS IN IEC BAFFLE	0.4 g
		SUSPENSION COMPLIANCE	1.4 mm/N
VOICE COIL DIAMETER	26 mm	SUSPENSION MECHANICAL RESISTANCE	1.5 Ns/m
VOICE COIL HEIGHT	16 mm	EFFECTIVE PISTON AREA	80 sq.cm
AIR GAP HEIGHT	6 mm		
LINEAR COIL TRAVEL (p-p)	10 mm	VAS	12 Litres
MAXIMUM COIL TRAVEL (p-p)	20 mm	QMS	1.7
MAGNETIC GAP FLUX DENSITY	1.25 T	QES	0.48
MAGNET WEIGHT	0.42 Kg	QTS	0.37
TOTAL WEIGHT	1.29 Kg		

* = IEC 268-5