

DX 1" Tweeter



Type Number: DX25TG05-04

Features:

In this tweeter design, Vifa audio engineers have tried to reinvent the traditional dome tweeter. Based on the knowledge obtained from work on the XT series, Vifa's R&D team combined a traditional dome design with the large surround of the XT. This results in a tweeter that has a very good dispersion and low distortion, due to the improved control of the diaphragm.

Driver Highlights: dome tweeter, fabric diaphragm, High sensitivity, High Dispersion



Specs:

Electrical Data

Nominal impedance	Zn	4	ohm
Minimum impedance	Zmin	--	ohm
Maximum impedance	Zo	19	ohm
DC resistance	Re	2.75	ohm
Voice coil inductance	Le	--	mH

T-S Parameters

Resonance Frequency	fs	650	Hz
Mechanical Q factor	Qms	4.32	
Electrical Q factor	Qes	0.79	
Total Q factor	Qts	0.67	
Force factor	Bl	2.2	Tm
Mechanical resistance	Rms	0.47	Kg/s
Moving mass	Mms	0.42	g
Suspension compliance	Cms	--	mm/N
Effective cone diameter	D	--	cm
Effective piston area	Sd	7	cm ²
Equivalent volume	Vas	--	ltrs
Sensitivity (2.83V/1m)		93.5	dB

Power handling

Long-term Max Power (IEC 18.3)	--	W
Short Term Max power (IEC 18.2)	--	W

Voice Coil and Magnet Parameters

Voice coil diameter	25	mm
Voice coil height	--	mm
Voice coil layers	--	
Height of the gap	2	mm
Flux density of gap	--	mWb
Total useful flux	--	mWb
Diameter of magnet	--	mm
Height of magnet	--	mm
Weight of magnet	--	Kg

Notes:
IEC specs refer to IEC 60268-5 third edition.
All Tympany products are RoHS compliant.

Frequency:

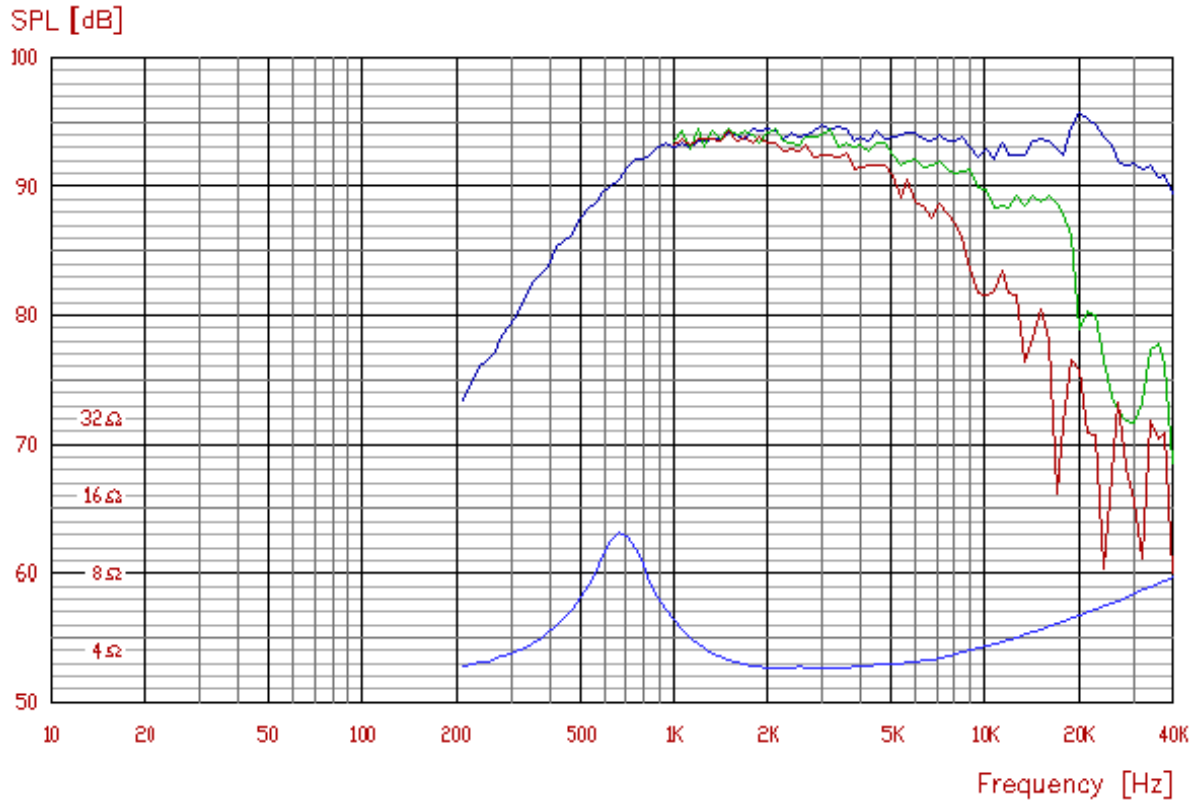

Mechanical Dimensions:

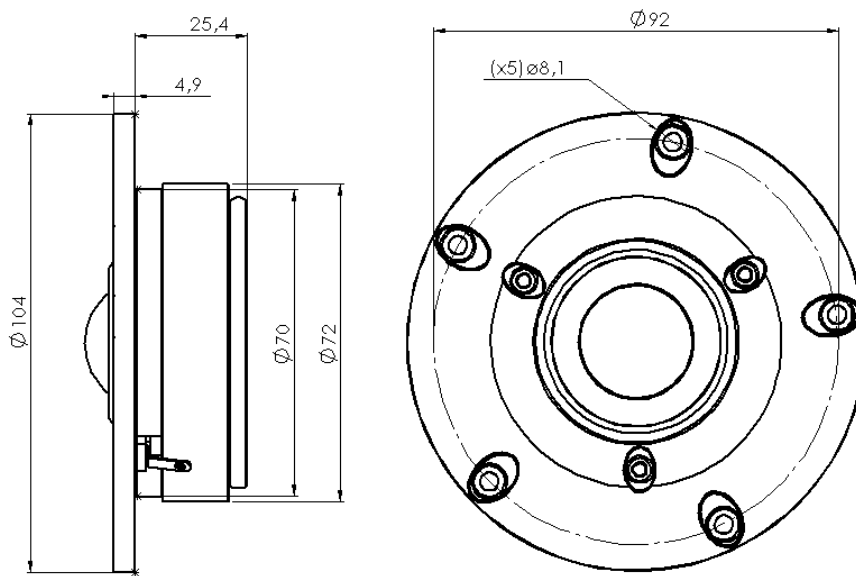

DX25TG05-04