

## 5¼" Midwoofer

Type Number: M13SG-09-08

### Features:

Driver Highlights: 5½" midwoofer, alu-chassis, coated paper cone, magnetically shielded



### Specs:

#### Electrical Data

Nominal impedance	Zn	8	ohm
Minimum impedance	Zmin	--	ohm
Maximum impedance	Zo	--	ohm
DC resistance	Re	5.6	ohm
Voice coil inductance	Le	0.7	mH

#### T-S Parameters

Resonance Frequency	fs	54	Hz
Mechanical Q factor	Qms	1.5	
Electrical Q factor	Qes	0.46	
Total Q factor	Qts	0.35	
Force factor	Bl	5.2	Tm
Mechanical resistance	Rms	--	Kg/s
Moving mass	Mms	6.5	g
Suspension compliance	Cms	--	mm/N
Effective cone diameter	D	--	cm
Effective piston area	Sd	80	cm <sup>2</sup>
Equivalent volume	Vas	12	ltrs
Sensitivity (2.83V/1m)		88	dB
Ratio BL/√(Re)		--	
Ratio fs/Qts	F	--	

#### Power handling

100h RMS noise test (IEC)	--	W
Long-term Max Power (IEC 18.3)	--	W
Max linear SPL (rms) @ power	--	dB/W
Short Term Max power (IEC 18.2)	--	W

#### Voice Coil and Magnet Parameters

Voice coil diameter	25	mm
Voice coil height	10	mm
Voice coil layers	--	
Height of the gap	6	mm
Linear excursion +/-	--	mm
Max mech. excursion +/-	--	mm
Flux density of gap	--	mWb
Total useful flux	--	mWb
Diameter of magnet	--	mm
Height of magnet	--	mm
Weight of magnet	0.344	Kg

Notes:  
IEC specs refer to IEC 60268-5 third edition.  
All Tympany products are RoHS compliant.

## Frequency:

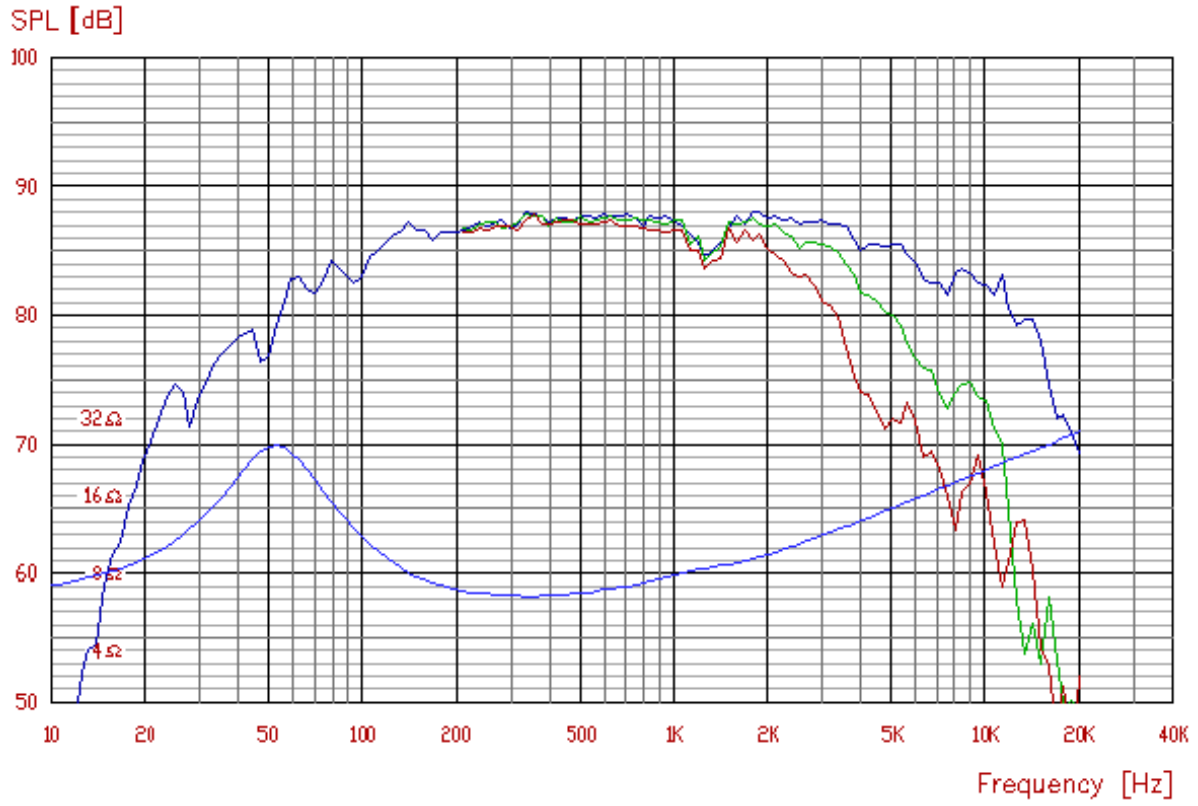

## Mechanical Dimensions:

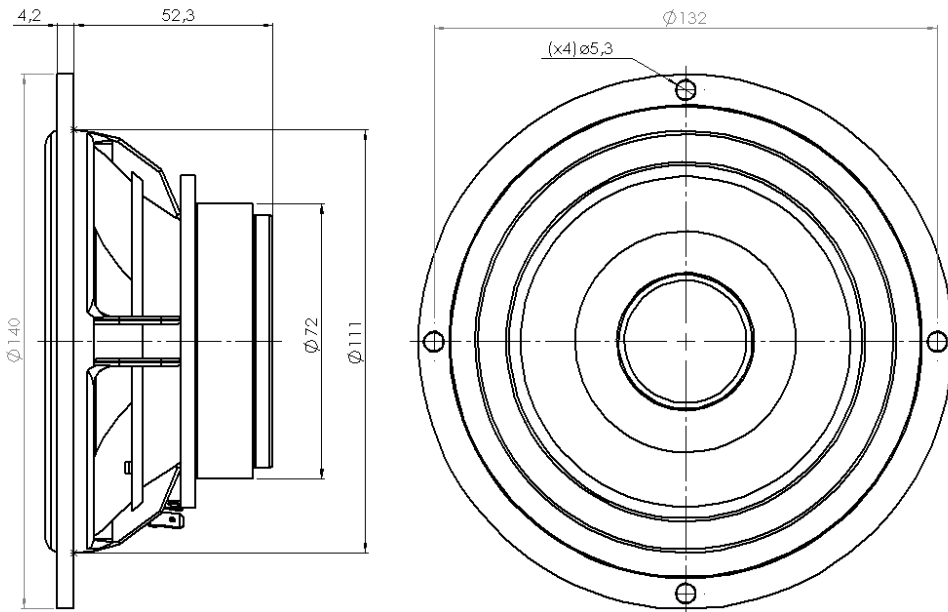

M13SG-09-08