

Model Number: NE315W-04
Description: Vifa NE Woofer 12"

Revision: rev 2_0
Date: 1-Sep-09



The Vifa NE product line has leading-edge transducer technology packaged in a cutting edge, stylistic design. The subwoofers in this product line feature an innovative cast aluminium basket design which minimizes acoustic reflections inside the driver, through large basket windows and sculpted basket spokes. The basket also is designed to act as a highly coupled heat sink to the NdFeB motor, so as to improve power handling capacity. An additional heat sink is available to provide extra thermal protection if needed. The cone and dust cap are constructed of natural wood fiber material with proprietary coating formulas & processes, so as to yield high clarity products. The cone designs also utilize pentacone technology for improved frequency response. The voice coil bobbin is titanium, for improved performance. The FEA-designed motor features copper caps to minimize inductance and extend performance to high frequencies. Rounding out the design is a 4-way terminal block connector, for ease of electrical connection.

Mechanical 2D Drawing:

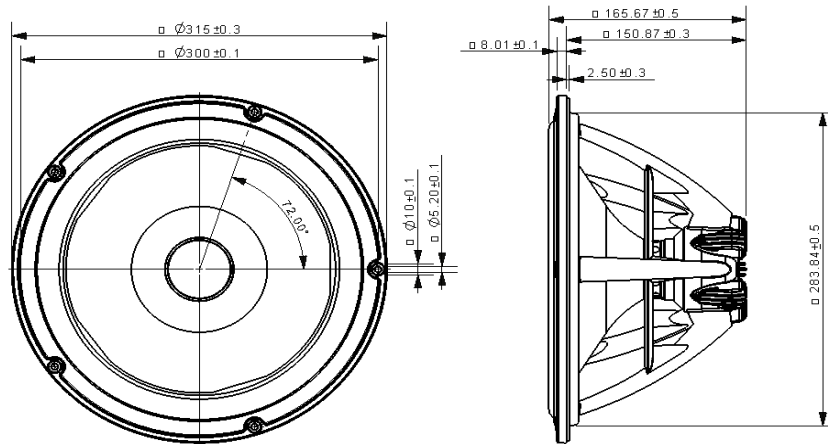

Specifications:

DC Resistance	R_{vc}	Ω	2.8	Energy Bandwidth Product	EBP	$(1/Q_{es})f_s$	63
Minimum Impedance	Z_{min}	Ω	3.6	Moving Mass	M_{ms}	g	113.91
Voice Coil Inductance	L_e	mH	0.38	Suspension Compliance	C_{ms}	um/N	559.2
Resonant Frequency	f_s	Hz	20	Effective Cone Diameter	D	cm	25.4
Mechanical Q Factor	Q_{ms}	-	15.6	Effective Piston Area	S_D	cm ²	506.7
Electrical Q Factor	Q_{es}	-	0.32	Equivalent Volume	V_{as}	L	201.66
Total Q Factor	Q_{ts}	-	0.31	Motor Force Factor	BL	T-m	11.12
Ratio f_s / Q_{ts}	F	f_s / Q_{ts}	64	Motor Efficiency Factor	β	$(T \cdot m^2) / \Omega$	44.58
Half Space Sensitivity @ 2.83V	dB@2.83V/1m	dB	88.6	Voice Coil Former Material	VC_{fm}	-	TiSV
Rated Noise Power (IEC 2685 18.1)	P	W	150	Voice Coil Inner Diameter	VC_d	mm	51.3
Test Spectrum Bandwidth	25 Hz - 1000Hz	12 dB/Oct		Maximum Linear Excursion	X_{max}	mm	9.00
				Transducer Mass	-	kg	2.68

Frequency and Impedance Response:

