

1" Tweeter

Type Number: MG27SG29-04

Features:

Driver Highlights: 1" dome tweeter, fabric diaphragm, ferrofluid, wide dispersion design, magnetically shielded



Specs:

Electrical Data

Nominal impedance	Zn	4	ohm
Minimum impedance	Zmin	--	ohm
Maximum impedance	Zo	--	ohm
DC resistance	Re	3	ohm
Voice coil inductance	Le	--	mH

T-S Parameters

Resonance Frequency	fs	1050	Hz
Mechanical Q factor	Qms	2.76	
Electrical Q factor	Qes	0.9	
Total Q factor	Qts	0.68	
Force factor	Bl	2.5	Tm
Mechanical resistance	Rms	--	Kg/s
Moving mass	Mms	0.28	g
Suspension compliance	Cms	--	mm/N
Effective cone diameter	D	--	cm
Effective piston area	Sd	7.1	cm ²
Equivalent volume	Vas	0.006	ltrs
Sensitivity (2.83V/1m)		93.5	dB

Power handling

Long-term Max Power (IEC 18.3)	400	W
Short Term Max power (IEC 18.2)	950	W

Voice Coil and Magnet Parameters

Voice coil diameter	25	mm
Voice coil height	2	mm
Voice coil layers	--	
Height of the gap	2	mm
Flux density of gap	--	mWb
Total useful flux	--	mWb
Diameter of magnet	--	mm
Height of magnet	--	mm
Weight of magnet	0.14	Kg

Notes:
IEC specs refer to IEC 60268-5 third edition.
All Tymphany products are RoHS compliant.

Frequency:

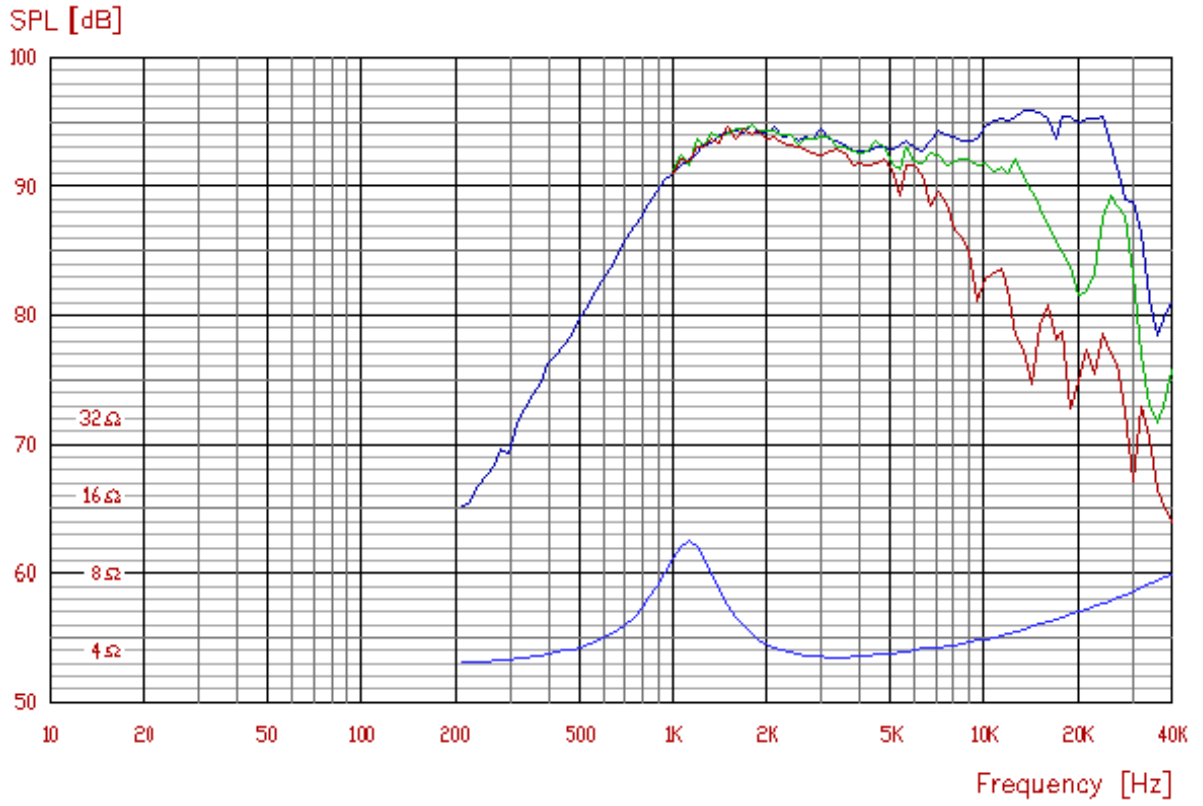

Mechanical Dimensions:

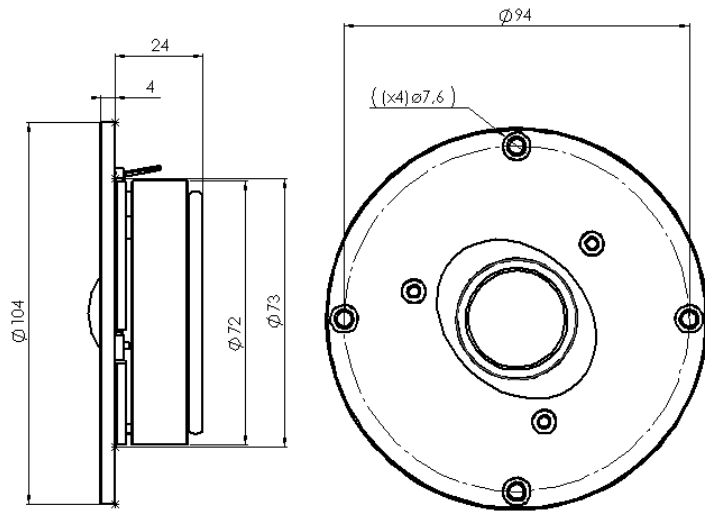

MG27SG29-04