

Model Number: NE25VTC-04
 Description: Vifa RM 25mm tweeter "Deep-Anodized Aluminum"

Revision: rev 1_0
 Date: Sep 4 09



The Vifa NE product line has leading-edge transducer technology packaged in a cutting edge, stylistic design. The tweeters in this product line finite element analysis designed Neodymium-Iron-Boron magnet (NdFeB) motors, with copper caps for extended frequency response and reduced distortion. The aluminium rear chambers offer extended low frequency performance, while doubling as heat sinking. The butterfly supporting the tweeter diaphragm is made of a high temperature plastic, consistent with the product's high temperature performance rating, and features supporting terminals. The dome material in this design is deep anodized aluminum, and the design has been optimized for sound quality and clarity. Rounding out the design is an aluminium face plate and plastic grille, which offers protection for the tweeter diaphragm.



Mechanical 2D Drawing:

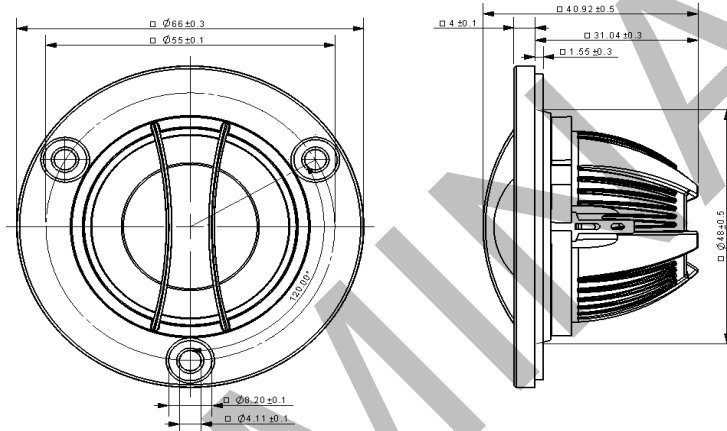

Specifications:

DC Resistance	R_{vc}	Ω	3.2	Energy Bandwidth Product	EBP	$(1/Q_{es})f_s$	608
Minimum Impedance	Z_{min}	Ω	3.62	Moving Mass	M_{ms}	g	0.37
Voice Coil Inductance	L_e	mH	0.01	Suspension Compliance	C_{ms}	um/N	136.0
Resonant Frequency	f_s	Hz	707	Effective Cone Diameter	D	cm	3.2
Mechanical Q Factor	Q_{ms}	-	5.4	Effective Piston Area	S_D	cm ²	8.0
Electrical Q Factor	Q_{es}	-	1.16	Equivalent Volume	V_{as}	L	0.01
Total Q Factor	Q_{ts}	-	0.96	Motor Force Factor	BL	T-m	2.13
Ratio f_s / Q_{es}	F	f_s / Q_{es}	738	Motor Efficiency Factor	β	$(T-m^2)/\Omega$	1.42
Half Space Sensitivity @ 2.83V	dB@2.83V/1m	dB	90.5	Voice Coil Former Material	VC_{fm}	-	Al
Rated Noise Power (IEC 2685 18.1)	P	W	na	Voice Coil Inner Diameter	VC_d	mm	25.8
Test Spectrum Bandwidth	2k-20kHz	12 dB/Oct		Maximum Linear Excursion	X_{max}	mm	0.10
				Transducer Mass	-	kg	0.1

Frequency and Impedance Response:

