

Model Number: NE95W-04
Description: Vifa FR 3"

Revision: rev 1_1
Date: 31-Aug-09



The Vifa NE product line has leading-edge transducer technology packaged in a cutting edge, stylistic design. The full-range drivers in this product line feature an innovative cast aluminium basket design which minimizes acoustic reflections inside the driver, through large basket windows and sculpted basket spokes. The basket also is designed to act as a highly coupled heat sink to the Neodymium-Iron-Boron magnet (NdFeB) motor, so as to improve power handling capacity. The cone is aluminium, with a butyl rubber surround designed through finite element analysis for linearity of performance. The voice coil bobbin is titanium, for improved performance. The FEA-designed motor features copper caps to minimize inductance and extend performance to high frequencies. Rounding out the design is a 4-way terminal block connector, for ease of electrical connection.



Mechanical 2D Drawing:

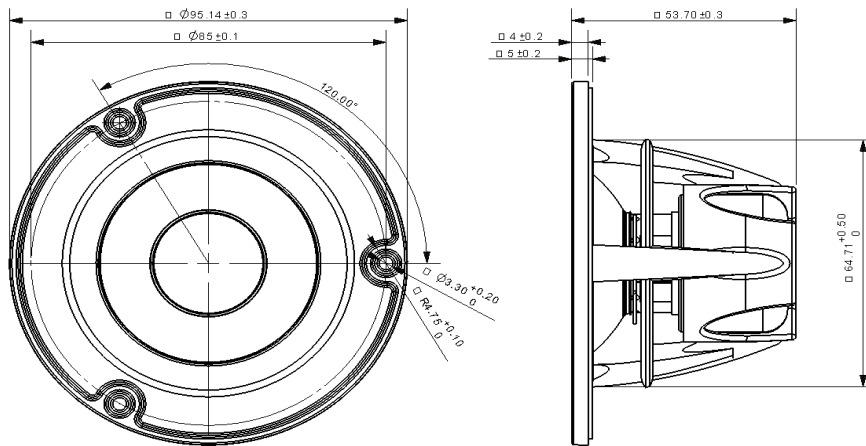

Specifications:

DC Resistance	R_{evc}	Ω	3.7	Energy Bandwidth Product	EBP	$(1/Q_{\text{es}}) \cdot f_s$	145
Minimum Impedance	Z_{min}	Ω	4.0	Moving Mass	M_{ms}	g	2.23
Voice Coil Inductance	L_e	mH	0.04	Suspension Compliance	C_{ms}	um/N	1175.4
Resonant Frequency	f_s	Hz	98	Effective Cone Diameter	D	cm	5.3
Mechanical Q Factor	Q_{ms}	-	9.1	Effective Piston Area	S_D	cm ²	22.1
Electrical Q Factor	Q_{es}	-	0.68	Equivalent Volume	V_{as}	L	0.81
Total Q Factor	Q_{ts}	-	0.63	Motor Force Factor	BL	T·m	2.74
Ratio f_s / Q_{ts}	F	f_s / Q_{ts}	156	Motor Efficiency Factor	β	$(T \cdot m^2) / \Omega$	2.03
Half Space Sensitivity @ 2.83V	$\text{dB} @ 2.83\text{V}/1\text{m}$	dB	85.1	Voice Coil Former Material	VC_{fm}	-	TiSV
Rated Noise Power (IEC 2685 18.1)	P	W	20	Voice Coil Inner Diameter	VC_d	mm	25.7
Test Spectrum Bandwidth	100Hz - 20000Hz	12 dB/Oct		Maximum Linear Excursion	X_{max}	mm	1.75
				Transducer Mass	-	kg	0.238

Frequency and Impedance Response:

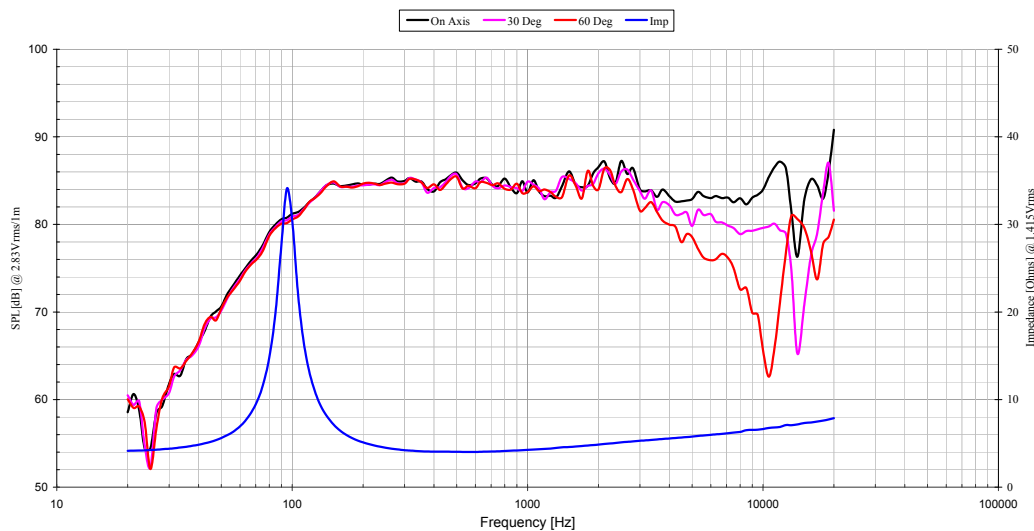

F088-0713A