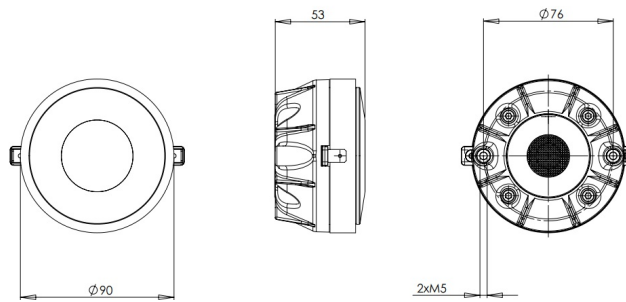

# DE10

**8Ω****HF Drivers - 1.0 Inches**

- 40 W continuous program power capacity
- 1" horn throat diameter
- 25 mm (1 in) aluminium voice coil
- Polyester diaphragm
- 1500 - 18000 Hz response
- 107 dB sensitivity

# DE10

HF Drivers- 1.0 Inches

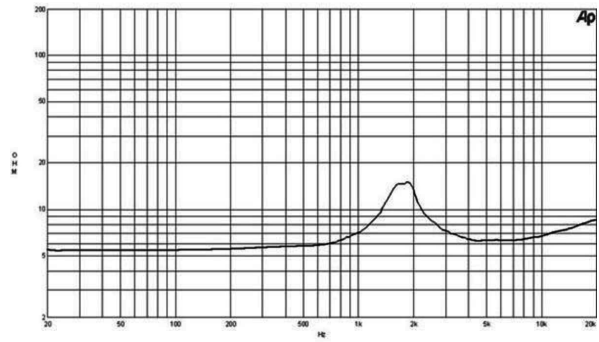
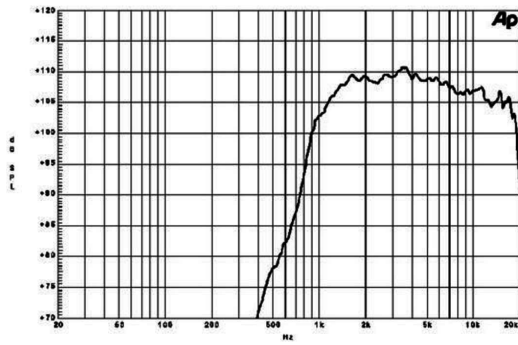

## SPECIFICATIONS<sup>1</sup>

Throat Diameter	25 mm (1.0 in)
Nominal Impedance	8 Ω
Minimum Impedance	6.3 Ω
Nominal Power Handling <sup>2</sup>	20 W
Continuous Power Handling <sup>3</sup>	40 W
Sensitivity <sup>4</sup>	107.0 dB
Frequency Range	1.5 - 18.0 kHz
Recommended Crossover <sup>5</sup>	2.5 kHz
Voice Coil Diameter	25 mm (1.0 in)
Winding Material	Aluminium
Inductance	0.1 mH
Diaphragm Material	Mylar
Flux Density	1.55 T
Magnet Material	Ferrite

## MOUNTING AND SHIPPING INFO

Two M5 holes 180° on 76 mm (3 in) diameter	
Overall Diameter	90 mm (3.5 in)
Depth	53 mm (2.1 in)
Net Weight	0.8 kg (1.8 lb)
Shipping Units	8
Shipping Weight	7.05 kg (15.54 lb)
Shipping Box	235x235x165 mm (9.25x9.25x6.50 in)

## SERVICE KIT

1. Driver mounted on B&C ME 10 horn.
2. 2 hour test made with continuous pink noise signal within the range from the recommended crossover frequency to 20 kHz. Power calculated on rated minimum impedance.
3. Power on Continuous Program is defined as 3 dB greater than the Nominal rating.
4. Applied RMS Voltage is set to 2.83 V for 8 ohms Nominal Impedance.
5. 12 dB/oct. or higher slope high-pass filter.