



## W 174.38 Fibonacci 8Ω

6,5" Woofer

Code ZH06500-8

The membrane design is the core of the "Fibonacci" collection by RS Speakers. The diaphragm features a custom para-elliptical profile, enhanced with a folded edge structure to increase rigidity in this critical area of the cone. The **patented "Fibonacci"** technology involves a precise erosion of the cone's outer surface by laser marker, following a path inspired by the Fibonacci sequence, named after the Italian mathematician who numerically defined the "Golden Ratio," a harmonious form found in nature. The primary advantage of this technology is the reduction of unwanted resonance modes in the cone. The **diaphragm** is treated with an acrylic coating on the front and a damping layer on the back, creating a "sandwich" structure that balances rigidity and damping. Special attention has been given to the **suspensions**, both in terms of geometry and materials: the NBR butyl rubber surround has a dual-wave profile to ensure symmetrical cone excursion. The **Conex spider** is meticulously crafted with controlled moulding depth to maximize excursion while minimizing dynamic offsets. The **voice coil** is built on a fiberglass former, maintaining perfect mechanical stability even at high temperatures and under extreme dynamic conditions. The **magnetic circuit** is designed to ensure maximum symmetry of the magnetic field flux in the gap, and an aluminum demodulating ring is included to reduce the overall inductance of the coil and harmonic distortion. Ventilation holes in the top plate and core reduce dynamic compression and turbulence. Every element of the tweeter woofer concurs in the quest for the purest sound, the ultimate target for RS.

- Unique custom design paper pulp cone "Fibonacci", patented technology
- Damping cone treatment
- Rubber surround with Double Asymmetric Rolls technology
- Conex spider with progressive waves
- 1,5" voice coil fiberglass former
- Ventilated magnet and voice coil to reduce power compression
- Ferrite magnet circuit with aluminum demodulating ring
- Free compression basket design: thin spokes to eliminate rear reflections of the cone

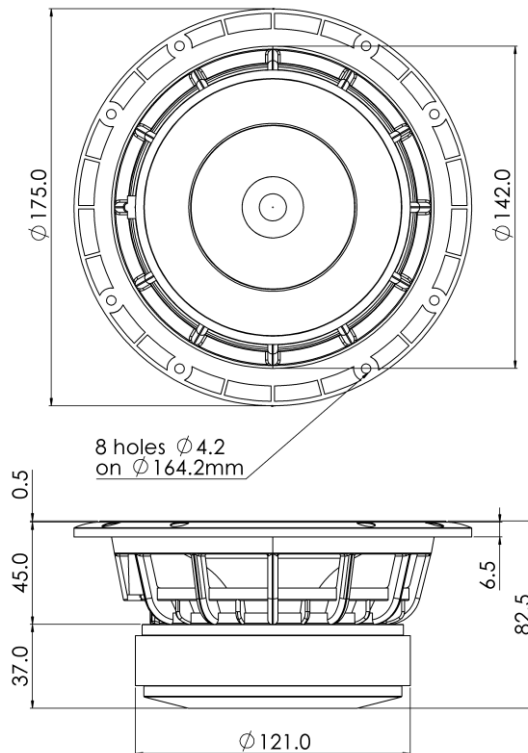

**pura passione**



## W 174.38 Fibonacci 8Ω

6,5" Woofer

Code ZH06500-8

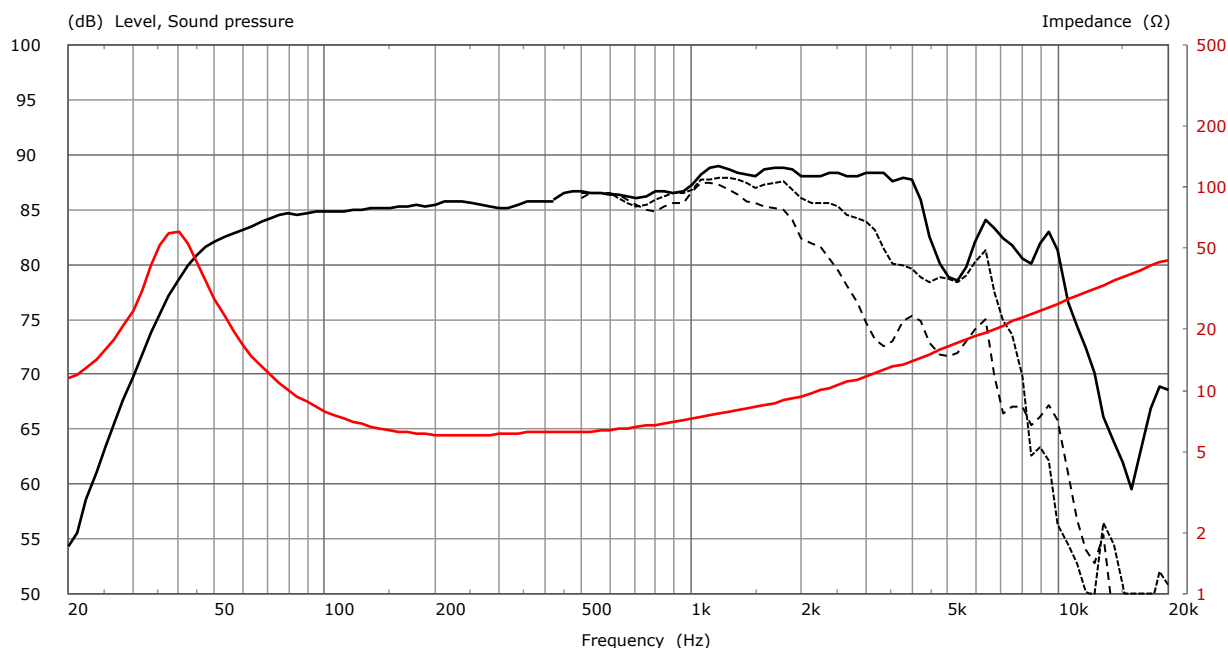

20-400Hz Frequency Response on 18 Lt @ 40 Hz Vented Box @ 1W, 1m  
400-20000Hz Frequency Response on IEC Baffle (DIN 45575) @ 25cm, normalized to SPL 1W,1m  
Dotted line off-axis Frequency response at 30°,60° - Free Air Impedance  
Measurement in Anechoic Chamber

### General Specifications

Nominal Diameter	174 mm (6.5")
Nominal Impedance	8 Ω
Rated Power AES <sup>(1)</sup>	130 W
Continuous Program Power <sup>(2)</sup>	260 W
Sensitivity @ 1W/1m <sup>(3)</sup>	88.9 dB
Voice Coil Diameter	38 mm (1.5")
Voice Coil Winding Depth	17 mm
Magnetic Gap Depth	5 mm
Flux Density	1.14 T
Magnet Weight	930 g
Net Weight	2.2 kg

### Thiele & Small Parameters<sup>(4)</sup>

Re	5.2 Ω	Fs	37.6 Hz
Qms	9.83	Qes	0.39
Qts	0.38	Mms	16.7 g
Cms	1073 μm/N	Bxl	7.24 Tm
Vas	22.9 l	Sd	122.7 cm <sup>2</sup>
X max <sup>(5)</sup>	+/-6.0 mm	X var <sup>(6)</sup>	+/-6.5 mm
ηo	0.30 %	Le (1kHz)	0.45 mH

### Constructive Characteristics

Magnet	Ferrite
Basket Material	Aluminium Die-Cast
Voice Coil Winding Material	Copper
Voice Coil Former Material	Fiberglass
Cone Material	Paper
Cone Treatment	Double Surface Damping Treatment
Surround Material	Rubber
Dust Dome Material	Solid Paper

### Mounting Information

Overall Diameter	175 mm
Baffle Cutout Diameter	143 mm
Mounting Holes	8 holes ø4,2 on ø164,2 mm
Total Depth	82.5 mm

(1) Rated Power measured with 2-hour test with pink noise signal, 6dB crest factor, loudspeaker in free air, power calculated on rated Zmin. (2) Power on Continuous Program is defined as 3dB greater than the Rated Power. (3) Calculated by Thiele & Small parameters, for SPL average in box refer to frequency response. (4) Thiele & Small parameters measured with laser system after preconditioning test. (5) Measured with respect to a THD of 10%. (6) Value corresponding to a decay of the Force Factor, or Compliance, or both, equal to the 50% of the small signal value. (7) Drawing dimensions: mm.  
Due to continuing product improvement, the features and the design are subject to change without notice.

pura passione